

»» 837 Series Water Closet Carrier

Off-The-Floor Water Closet Carriers

Off-the-floor water closets are mounted to steel threaded rods, which are attached to a support or 'carrier' behind the finished wall. This carrier is anchored to the floor and bears the load of the fixture.

The most obvious advantages of off-the-floor water closets are installation and sanitation/maintenance.

Installation Benefits

Floor-mounted water closets require a slab penetration at each location. Waste piping must then run under the slab, which in multi-story buildings, requires accessible concealment in the ceiling of the floor below.

In contrast, off-the-floor installations do not require slab penetration in the toilet room. Since all piping is behind the wall, there is no need for ceiling modification. Off-the-floor support systems also allow for prefabrication, which can save time.

Sanitation/Maintenance Benefits

Although floor mounted and off-the-floor installations have similar mechanical service requirements, off-the-floor installations are generally considered easier to service and maintain.

The ability to maintain a clean environment is one of the most important considerations in toilet room design. Cleaning under off-the-floor fixtures is much easier than cleaning around and behind floor-mounted water closets. Deterioration of the floor where the fixture is mounted can also contribute to unsanitary conditions.

Note: Local building or plumbing codes may require modifications to the information provided. Consult local codes before installation. If this guide is not consistent with local building or plumbing codes, the local codes should be followed.

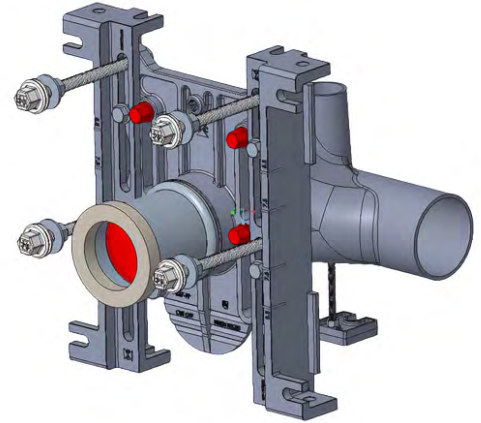

Standard

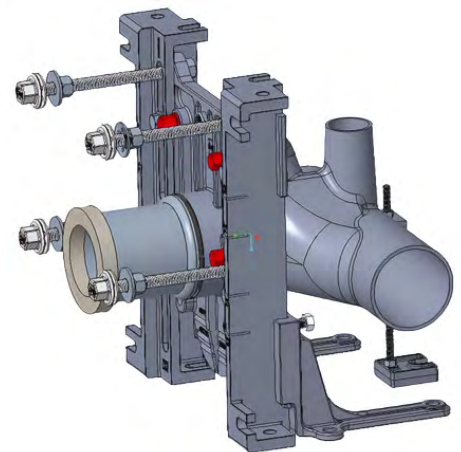

Extra-Heavy

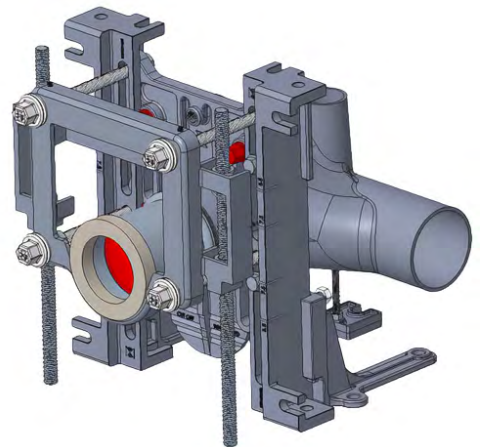

Bariatric

837 Series Water Closet Carrier

STEP 1: Determine the flow direction of the closet carrier fitting by **FACING THE BOWL**

If the flow is **FROM the RIGHT**, a right-hand fitting is required

If the flow is **FROM the LEFT**, a left-hand fitting is required

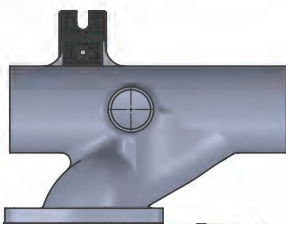

Horizontal Single Carrier Fitting - Left Hand

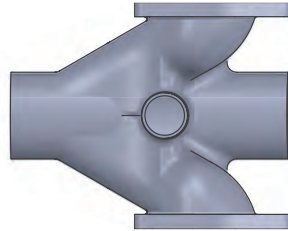

Horizontal Double Carrier Fitting

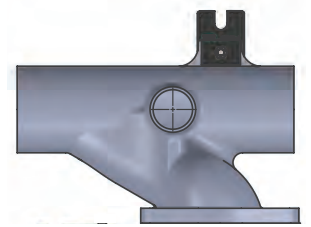

Horizontal Single Carrier Fitting - Right Hand

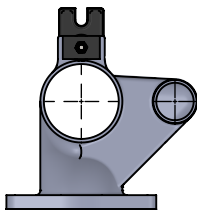
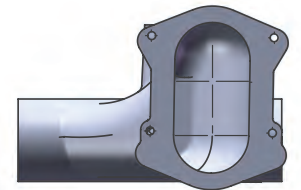
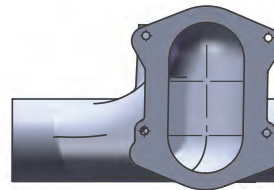
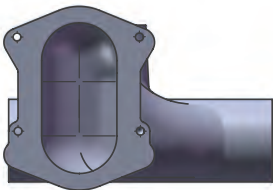

Vertical Single Carrier Fitting Two Side Inlets¹

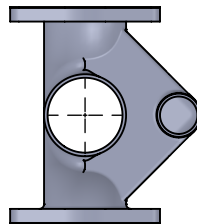

Vertical Double Carrier Fitting Two Side Inlets¹

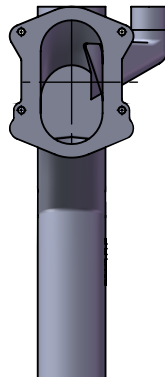
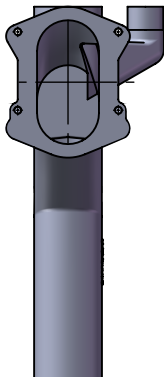

Flow FROM the RIGHT = Right Hand Carrier

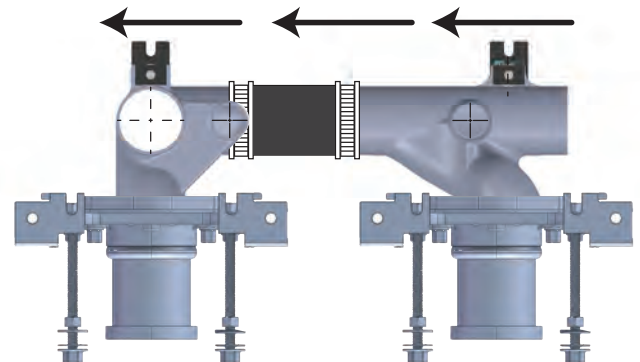

Flow FROM the LEFT = Left Hand Carrier

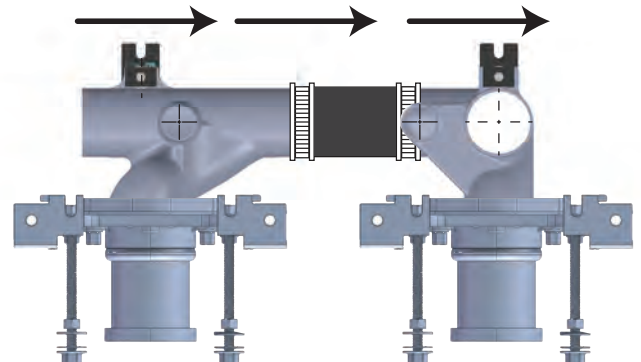

¹ For vertical carriers having a right-side inlet, left-side inlet, or no inlets, a factory-installed cap is used on one or both side inlets of the supplied fitting

Installation Guide

837 Series Water Closet Carrier

STEP 2: Verify all components of the faceplate assembly

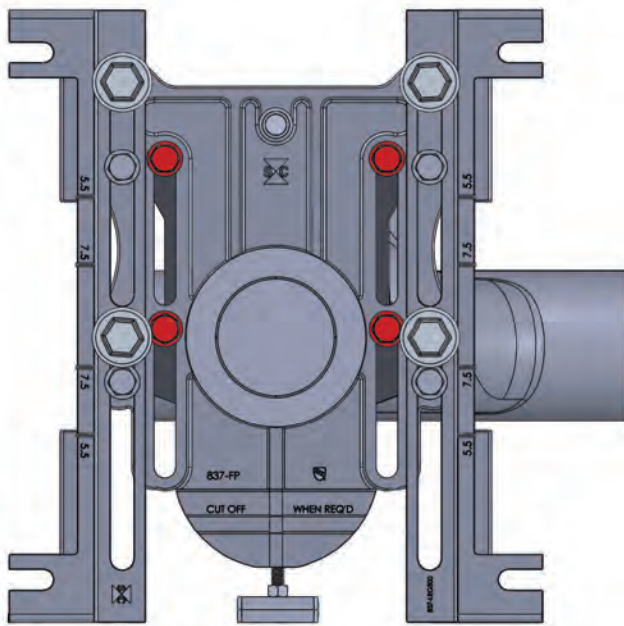

837-NRH
Rough-in Hardware Kit

1/2" x 1-1/2"
Tall-Head Bolts (4)

5/8" Hex Nuts (4)

Faceplate Gasket

837-NFH
Finish Hardware Kit

5/8" Cap Nuts (4)

5/8" Hex Nuts (4)

5/8" Metal Washers (4)

5/8" Plastic Washers (4)

Fixture Gasket

837-NRA
Rear Anchor Kit

3/8" Hex Nuts (3)

Washers:
- Square (1)
- 1/2" (1)
- 3/8" (2)

Anchor Foot (1)

3/8" x 10" Threaded Rod (1)

837-NTR
Threaded Rod Kit

5/8" x 9" Threaded Rod with Sleeve (4)

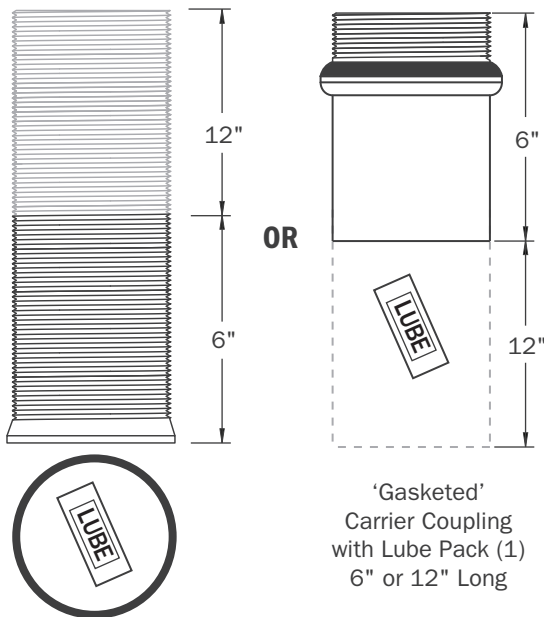

Threaded Carrier Coupling with O-ring & Lube Pack (1)
6" or 12" Long

837 Series Water Closet Carrier

STEP 3: Slide gusset support into place on carrier leg and tighten.

STEP 4: Place the faceplate gasket on the face of the cast iron or PVC carrier fitting. Align the four holes in the gasket with the four tapped holes in the carrier fitting. Be sure the words 'UP' on gasket are positioned at the top of the carrier fitting face.

STEP 5: Place carrier fitting against the back of faceplate/leg assembly such that the gasket is sandwiched between the back of the faceplate and the carrier fitting. Align the four fitting holes with four inner slots on faceplate. Using the four (red) tall-head bolts, snugly attach the fitting to faceplate/leg assembly. Do not tighten completely at this point.

STEP 6: From the fixture manufacturer's rough-in sheet, determine the rough-in height of the fixture outlet. Loosen the four leg bolts and adjust the height of the faceplate to the required rough-in height. For low rough-in heights, portions of the 'breakaway' area at the bottom of the faceplate may need to be removed, along the scored lines. Once rough-in height is set, tighten the four leg bolts completely using a wrench (25-35 lb-ft of torque). Be sure the bottom of the legs remain flat and parallel when adjusting the height.

STEP 7: With the faceplate/fitting assembly standing upright, loosen the four (red, tall-head) faceplate bolts and adjust the waste line height and pitch as needed. Re-tighten the four faceplate bolts completely using a wrench (25-35 lb-ft of torque).

STEP 8: For 'single' cast iron fittings, attach the rear anchor (see instructions provided). Be sure the anchor foot sits flat and level on the floor and nuts are tightened.

STEP 9: Position the carrier assembly in place. Secure the legs, gussets and rear anchor (if cast iron fitting) to the concrete floor using 1/2" (min diameter) anchors (not provided).

See below for required/optional fastener locations

ITEM NO.	FIG.	QTY.	DESCRIPTION
837-NFPAH Face Plate Assembly	837-NRH Rough-in Hardware Kit	A	4 1/2" Tall-Head Bolt
		B	4 5/8" Hex Nut
		C	1 Faceplate Gasket
		D	4 5/8" Cap Nut
		E	4 5/8" Hex Nut
	837-NFH Finish Hardware Kit	F	4 5/8" Metal Washer
		G	4 5/8" Plastic Washer
		H	1 Fixture Gasket
	837-NRA Rear Anchor Kit	I	1 Rear Anchor & Hardware
	837-NTR Thread Rod Kit	J	1 5/8" Threaded Rod & Sleeve (4pcs)
	K	1 Faceplate	
	L	2 Support Leg	
	M	2 Gusset Support (left & right)	

All item numbers in **BOLD** are available for sale

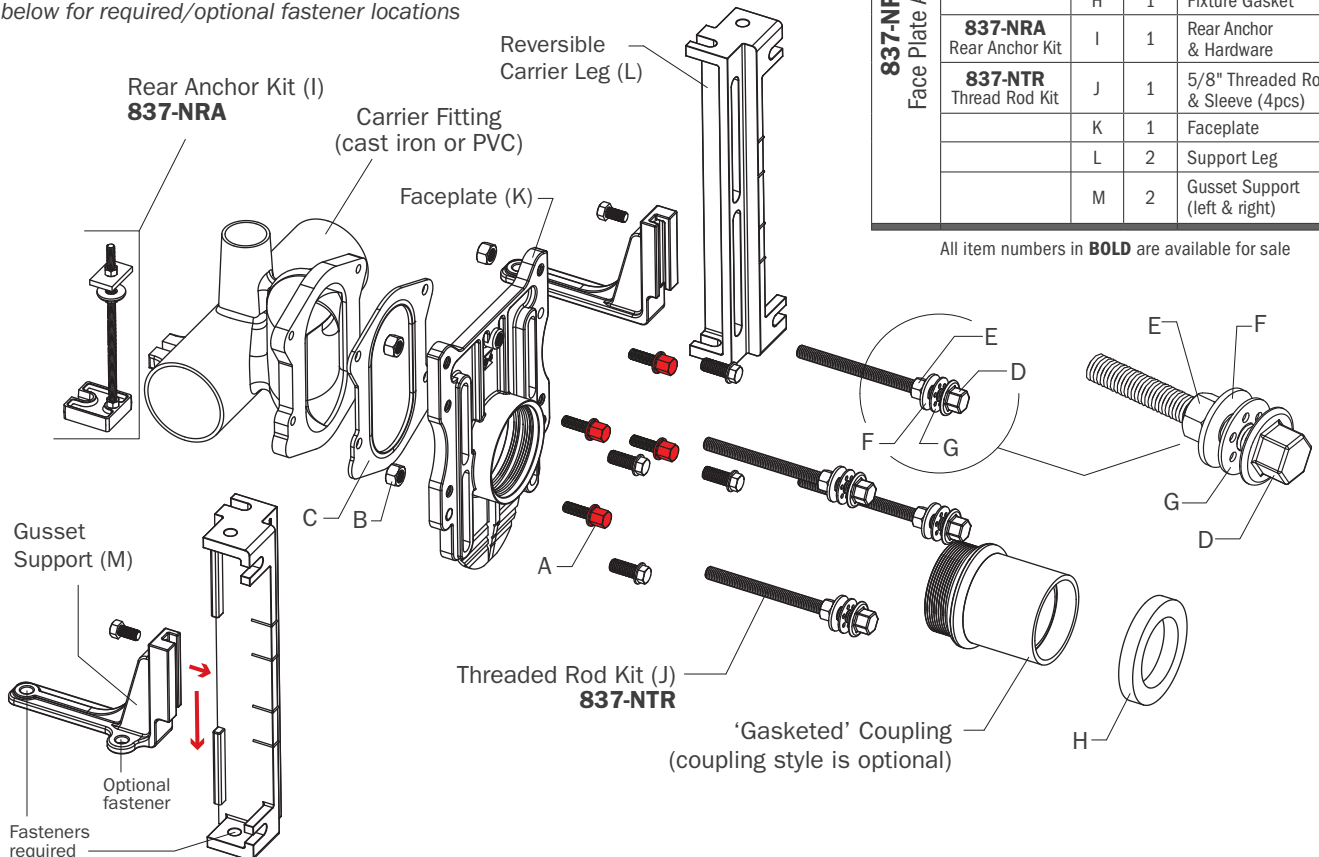

837 Series Water Closet Carrier

STEP 10: Thread the four threaded rods through the leg slots and into the faceplate. Adjust the rods so that they will extend X" beyond the finished wall (X = the thickness of the fixture mounting flange, + 11/16"). Lock rods in place with 5/8" hex nuts. Note: if rods are too long, they may prevent proper compression of the gasket between the fixture and the carrier coupling. Slide plastic sleeves over the four threaded rods. If desired, the 837-TF tiling frame (available separately) can be installed prior to finished wall installation.

STEP 11: Determine which carrier coupling will be used.

If using 837-S06 / 837-S12 'Gasketed' Couplings: The carrier coupling should protrude out approx. 5/16" beyond the finished wall, or as determined by the fixture manufacturer's recommendation. If the coupling must be cut to shorten, be sure to make a 90° cut and smooth/deburr the end, so that the cut end of the coupling will make a flat/even compression seal with the fixture gasket. Be sure the beveled surface of the faceplate inlet is clean and smooth. Lubricate the gasket on the carrier coupling and thread the coupling into the faceplate. Tighten the coupling completely using a strap wrench to make sure the gasket makes a positive seal between the coupling and the faceplate. Do Not use sealant on the coupling threads. Once the carrier coupling is installed, pressure test the fixture carrier assembly according to local code requirements.

If using 837-06 / 837-12 Threaded Couplings: The carrier coupling should protrude out approx. 5/16" beyond the finished wall, or as determined by the fixture manufacturer's recommendation. If the coupling must be cut to shorten, cut the threaded end. Smooth and deburr the cut end before threading into the faceplate to prevent damage to the o-ring. Insert the o-ring (included with threaded coupling) into the groove in the threaded opening of the faceplate. Lubricate the o-ring and coupling threads generously with lube provided. Thread the coupling into the faceplate until it engages the o-ring. Using a strap wrench or bar tool, continue threading the coupling into/past the o-ring to make a positive seal between the coupling and the faceplate. Installation of the o-ring is critical. Carefully inspect the o-ring and faceplate groove. Improper installation of the o-ring may cause a leak behind the finished wall. Once the carrier coupling is installed, pressure test the fixture carrier assembly according to local code requirements.

STEP 12: Following a successful system test and installation of the finished wall, knock out the carrier coupling's test cap and remove any sharp edges or debris.

STEP 13: Thread a 5/8" nut and steel flat washer on to each of the four threaded rods. Adjust the nut/washer so they allow a 1/16" gap between the back of the fixture and the finished wall surface. Minor adjustments may be necessary as the back of the fixture may not be completely flat.

STEP 14: Remove fixture gasket from the box and remove center portion. Peel backing from one side and push sticky side of gasket firmly into recess around fixture outlet.

STEP 15: Before setting the fixture, confirm the position of the carrier coupling to be sure it will make flat, compressed contact with fixture gasket around the fixture outlet. Peel remaining backing from fixture gasket. Carefully slide fixture completely over four threaded rods, making sure the fixture gasket makes a positive seal with the carrier coupling. Load four plastic washers over rods, then secure fixture using four polished 5/8" cap nuts. Tighten cap nuts by hand, then an additional 1/2-turn with a wrench. To reduce potential stress on the fixture flange, which can cause cracking under heavy loads, one of the four cap nuts may be left hand tight - this is at the discretion of the installer. The back of the fixture should remain 1/16" from the finished wall.

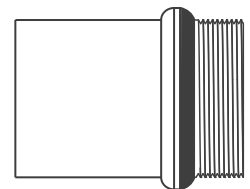
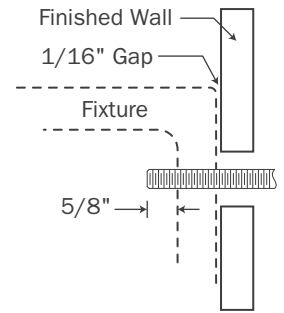

'Gasketed'
Carrier Coupling

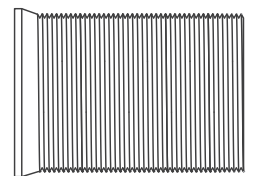

Threaded
Carrier Coupling

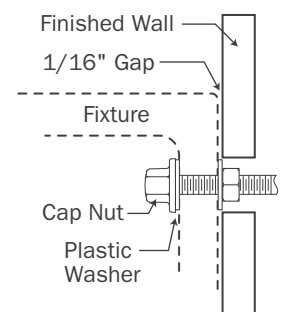

837 Series Water Closet Carrier

Basic Dimensions: Minimum wall chase requirements

Single Horizontal Adjustable Carrier Fittings

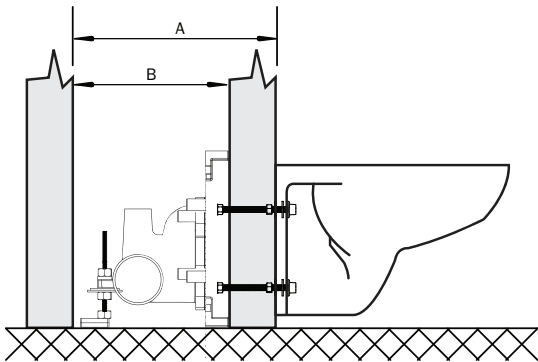

SINGLES		
Product No.	A	B
837-HS Series	13.16"	11.30"

Double Horizontal Adjustable Carrier Fittings

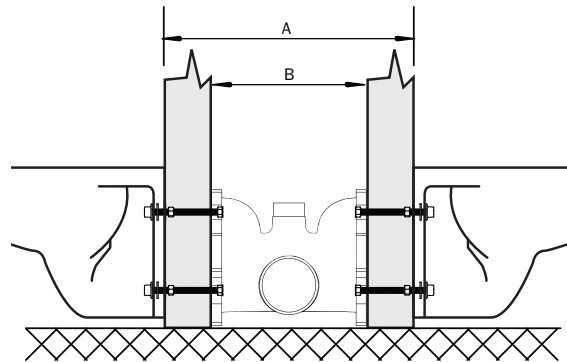

DOUBLES		
Product No.	A	B
837-HSD Series	16.95"	13.20"

Single Vertical Adjustable Carrier Fittings

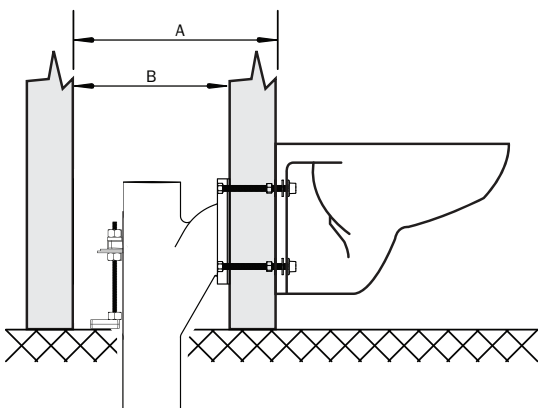

SINGLES		
Product No.	A	B
837-VS10 Series	13.16"	11.30"

Double Vertical Adjustable Carrier Fittings

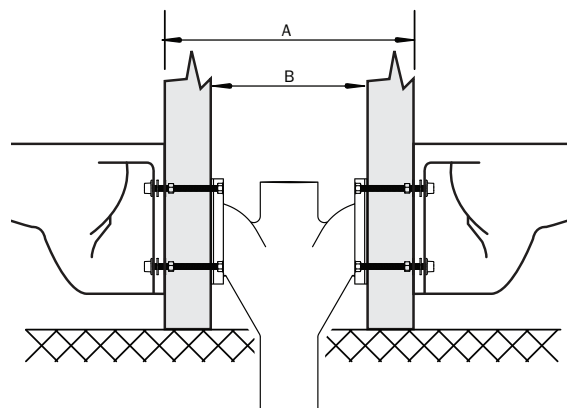

DOUBLES		
Product No.	A	B
837-VS20 Series	16.95"	13.20"

Installation Guide

837 Series Water Closet Carrier

Basic Dimensions: Standard Horizontal Carrier

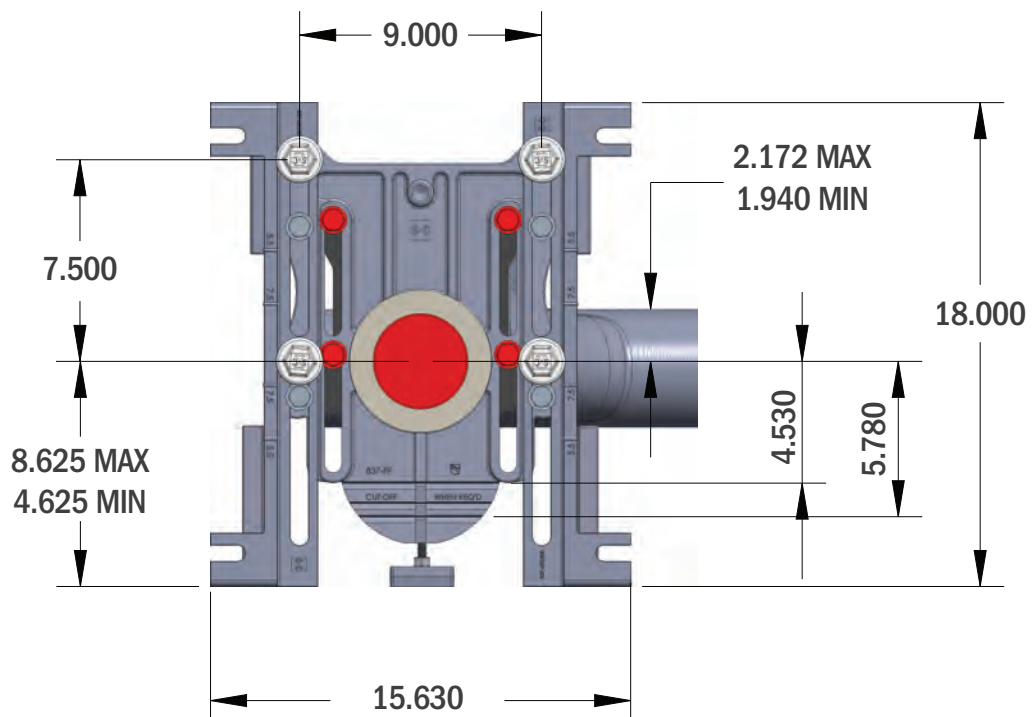
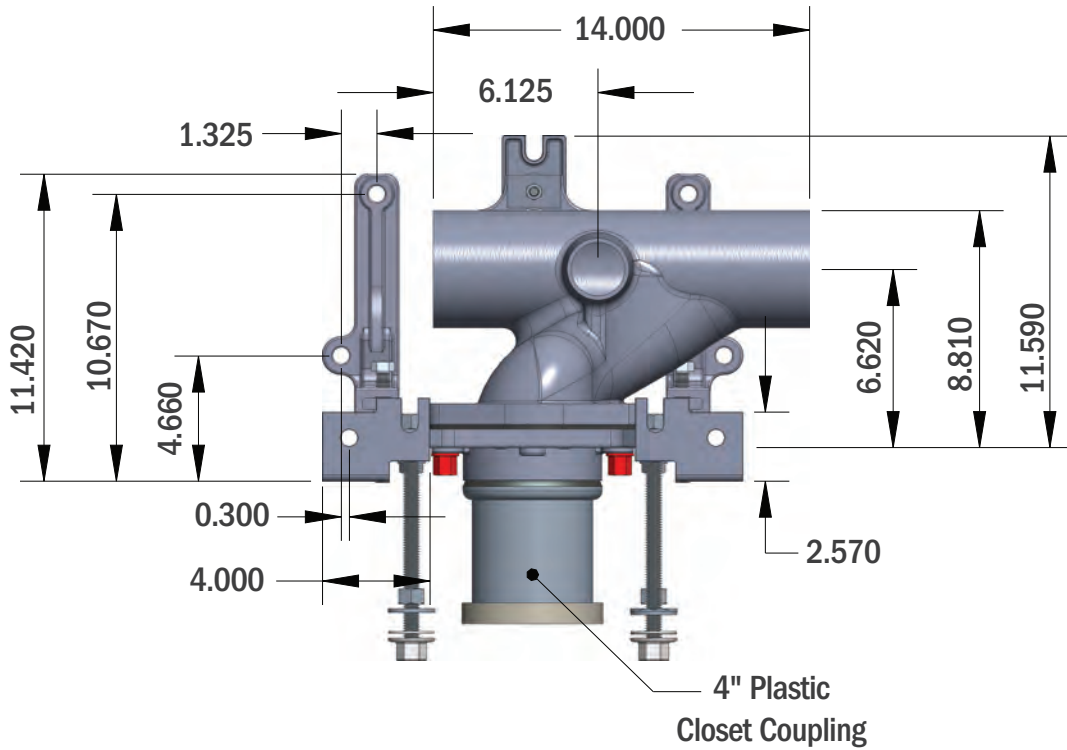

837 Series Water Closet Carrier

Basic Dimensions: Standard Vertical Carrier

